

ALLIED COMMERCIAL SPLIT SYSTEMS

www.alliedair.com

INDEX

SPLIT SYSTEM UNITS — R-410A — 60 HZ

TPA HEAT PUMP OUTDOOR UNITS	3-3
TSA CONDENSING UNIT	3-2
TAA AIR HANDLER.....	3-4

This section contains product and technical information only.

For additional information and product pricing please contact your local ECCO Supply Sales Branch.

ECCO is proud to be a member of:



ASHRAE
American Society of
Heating, Refrigerating, and
Air-Conditioning Engineers, Inc.
www.ashrae.org



HRAI
Heating, Refrigeration and
Air Conditioning
Institute of Canada
www.hrai.ca



HARDI
Heating, Airconditioning &
Refrigeration Distributors
International
www.hardinet.org



SMACNA
Sheet Metal and Air
Conditioning Contractors'
National Association
www.smacna.org



SPIDA
Spiral Duct
Manufacturers
Association
www.spida.org



CIPH
Canadian Institute
of Plumbing &
Heating
www.ciph.com

ALLIED COMMERCIAL SPLIT SYSTEMS

www.alliedair.com

SPLIT SYSTEM UNITS — R-410A — 60 HZ

TSA CONDENSING UNIT

- Up to 11.4 EER
- 6, 7.5, 10, 12.5, 15 and 20 nominal tons
- Cooling capacity – 66,000 to 236,000 BTUH
- One scroll compressor for 6, 7.5 and 10, two scroll compressors for 10, 12.5, 15 and 20 ton units
- High pressure switch, loss of charge switch, high capacity drier(s) and crankcase heaters are factory installed
- Optional factory installed corrosion protection option
- Optional field installed coil guards, hail guards and low ambient kit
- 1 year limited warranty** – parts
- 5 year limited warranty** – compressor

** See warranty certificate for complete details.

MODEL NUMBER IDENTIFICATION

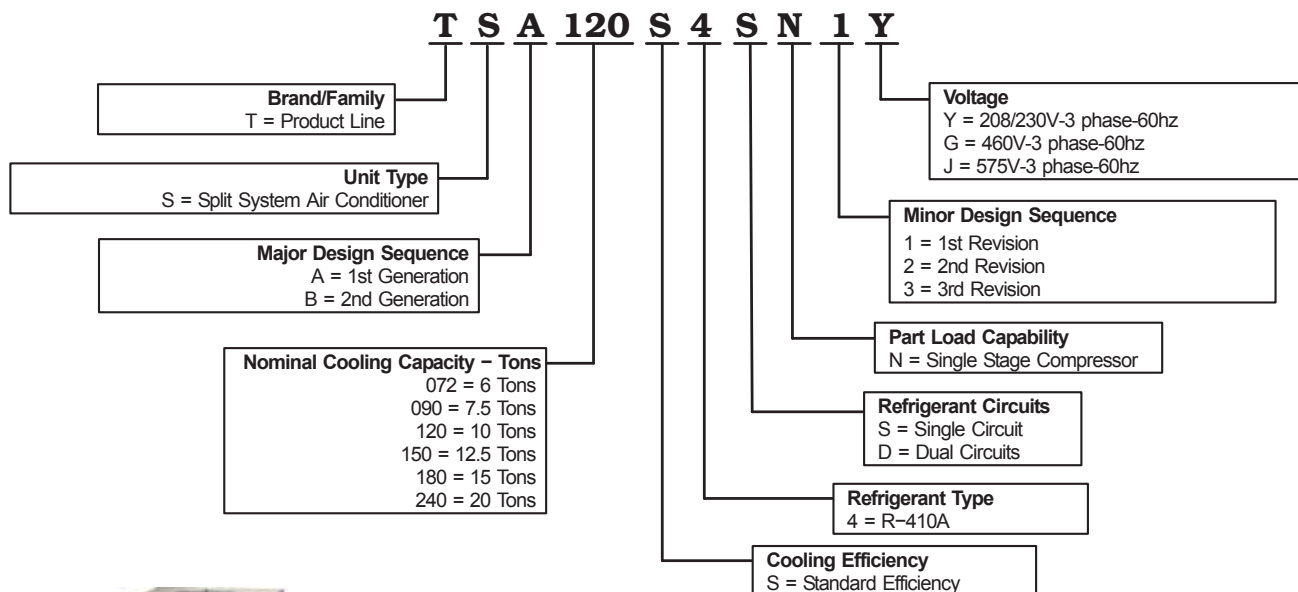

072-090 Models



120-150 Models



180-240 Models

– E.&O.E. – All Prices F.O.B. Our Warehouse – Subject to Change Without Notice – All Taxes Extra –

ALLIED COMMERCIAL SPLIT SYSTEMS

www.alliedair.com

SPLIT SYSTEM UNITS — R-410A — 60 HZ (cont'd)

TPA HEAT PUMP OUTDOOR UNITS

- Up to 11.4 EER
- 7.5 and 10 nominal tons
- Cooling capacity – 89,000 to 180,000 BTUH
- Heating capacity – 88,000 to 174,000 BTUH
- One scroll compressor for 7.5 and 10 ton units
- High pressure switch, loss of charge switch, high capacity drier(s) and crankcase heaters are factory installed
- Optional factory installed corrosion protection option
- Optional field installed coil guards, hail guards and low ambient kit
- 1 year limited warranty** – parts
- 5 year limited warranty** – compressor

** See warranty certificate for complete details.

MODEL NUMBER IDENTIFICATION

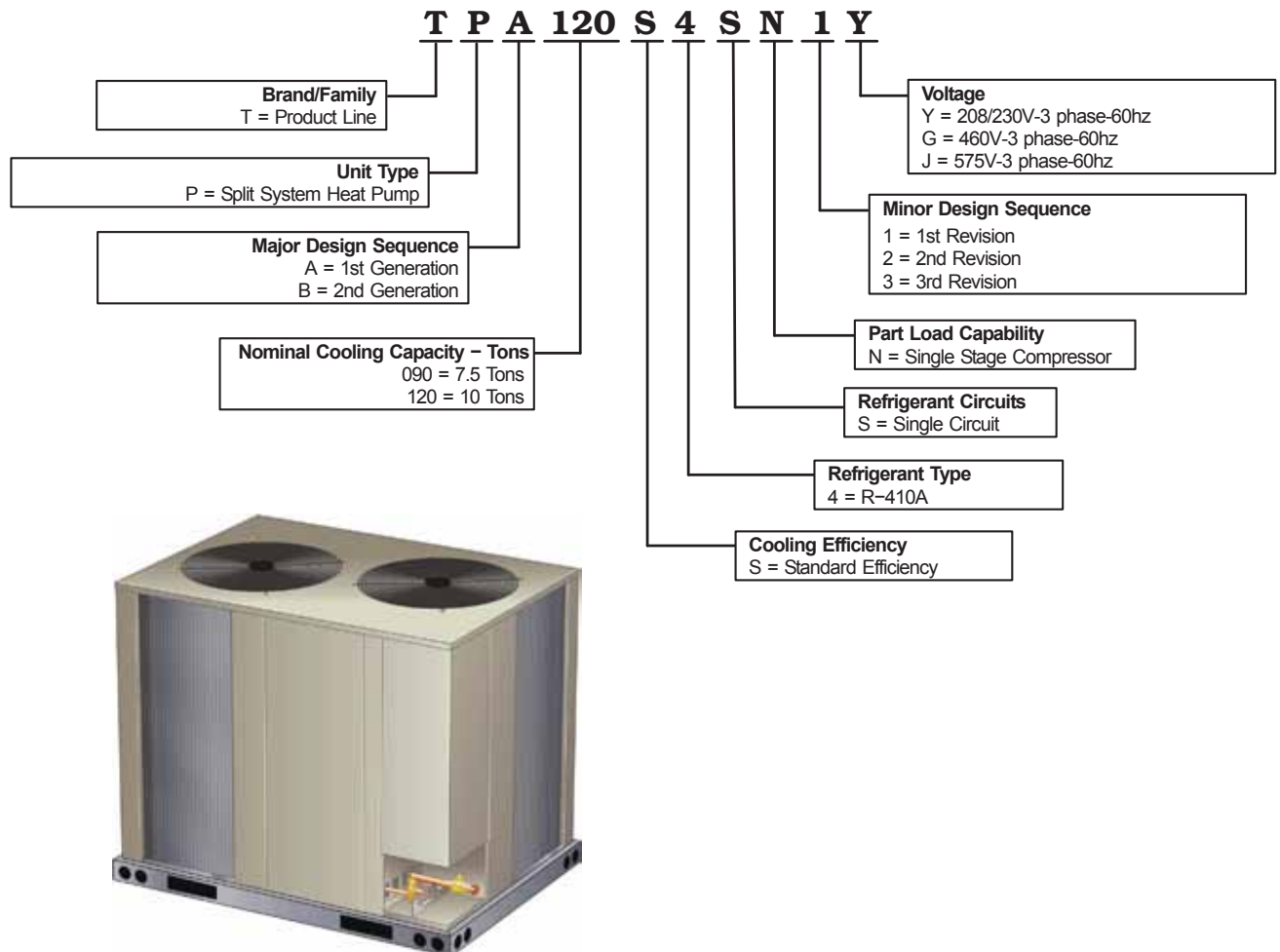

– E.&O.E. – All Prices F.O.B. Our Warehouse – Subject to Change Without Notice – All Taxes Extra –

ALLIED COMMERCIAL SPLIT SYSTEMS

www.alliedair.com

SPLIT SYSTEM UNITS — UPFLOW/HORIZONTAL — R-410A — 60 HZ

TAA AIR HANDLER

- 6, 7.5, 10, 12.5, 15 and 20 nominal tons
- Optional electric heat – 10 to 50 kW
- Convertible up-flow or horizontal design
- 50/50 face split coil
- Heavy-duty belt drive blower motors
- Equipped with single circuit for 6 ton and dual circuit for 7.5 - 20 ton
- Optional accessories include low or high static blower drives, freestat, corrosion protection, float switch and return air grilles
- Optional indoor air quality choices include a disposable MERV 10 or 16 filter, Healthy Climate® UVC germicidal light kits and an economizer damper section
- Electric heat section furnished in a separate add-on matching cabinet
- 1 year limited warranty** - parts

** See warranty certificate for complete details.

MODEL NUMBER IDENTIFICATION

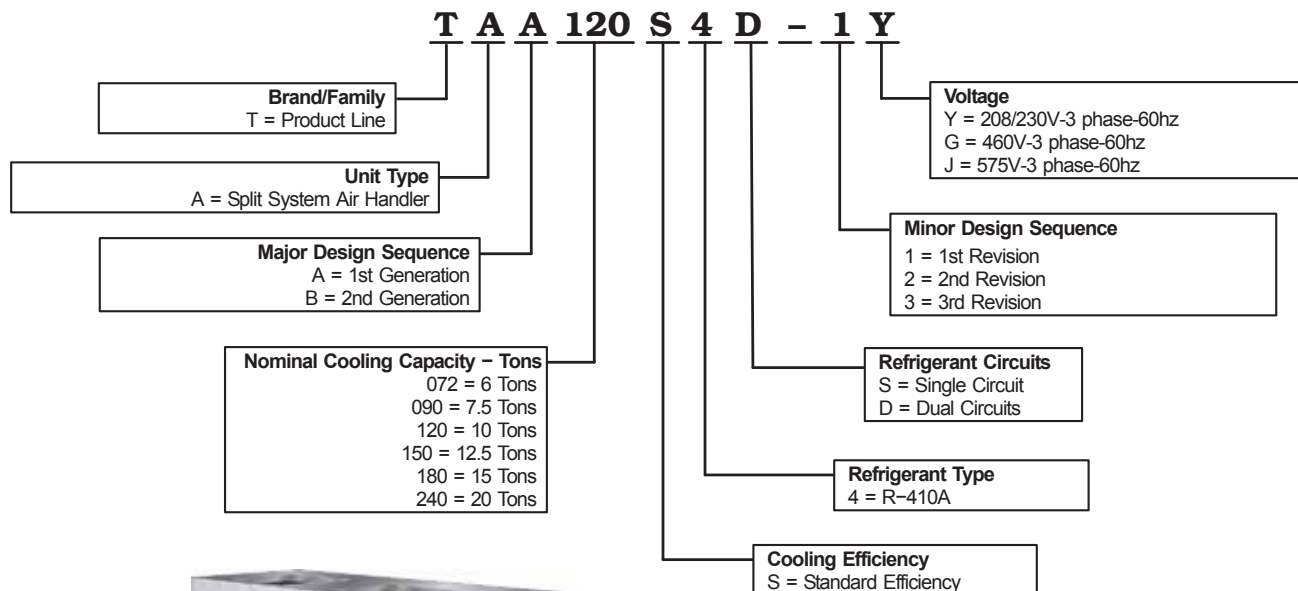

180-240 Models



072-090-120-150 Models

– E.&O.E. – All Prices F.O.B. Our Warehouse – Subject to Change Without Notice – All Taxes Extra –